

## REGAL 0835

### BENCHTOP VACUUM PACKER

#### STANDARD FEATURES

- Stainless steel housing and deep-drawn vacuum chamber with round corners for optimal hygiene
- Removable wireless sealing bar
- Insert plates for fast vacuum cycle and product adjustment
- Gentle air flow return for better product protection
- Optimal final vacuum 99.80% (2 mbar)
- 2 x 3.5mm seal wires for an extra-strong double seal
- Time control - Command in seconds for vacuum and seal
- STOP button for partial/full cycle interruption
- Digital maintenance program for pump
- Automatic reminder for oil replacement
- Service kit for user maintenance



#### DIMENSIONS

External: 450W x 554D x 365H mm

Chamber: 350W x 370D x 150H mm

Sealing Bar: 350mm

Weight: 35Kg

#### TECHNICAL DATA

Power Supply: 240V, 50Hz, Single Phase

Power Output: 0.4kW

Capacity pump: 8 m<sup>3</sup>/h

Machine cycle: 20-40 seconds

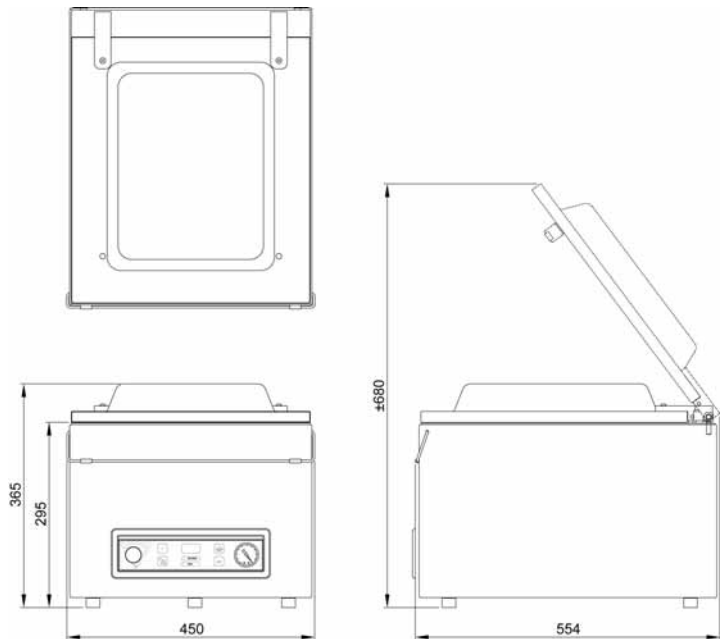

#### OPTIONS

- Inclined insert plate for packing liquid products
- Trolleys with 3 shelves and lockable castors



Busch vacuum pumps, world leaders in vacuum pump technology



Two years parts and labour warranty

SPECIFICATIONS ARE SUBJECT TO CHANGE WITHOUT NOTICE.

*From the world of Comcater!*

**National Head Office**  
156 Swann Drive  
Derrimut VIC 3030  
Tel: +61 3 8369 4600  
Fax: +61 3 8369 4695

**Melbourne**  
96-100 Tope Street,  
South Melbourne VIC 3205  
Tel: +61 3 8369 4600  
Fax: +61 2 8699 1299

**Sydney**  
20/4 Avenue of the Americas  
Newington, NSW 2127  
Tel: +61 2 9748 3000  
Fax: +61 2 9 648 4762

**Brisbane**  
1/62 Borthwick Avenue  
Murarrie QLD 4172  
Tel: +61 7 3399 3122  
Fax: +61 7 3399 5311