

Brema's flagship CB range offers self-contained ice machines for bench top, under bench or free-standing installation. These machines produce attractive, crystalline cubes weighing 13g which rapidly chill and enhance the appearance of any beverage.

The Brema CB640A is a free-standing ice cube machine that produces 67kg of ice per 24 hours and has storage capacity of 40kg.

The CB range of self-contained ice cube machines is the perfect fit for cafes, restaurants, hotels, bars and nightclubs.

STANDARD FEATURES

- 67kg production per 24 hours
- 40kg storage capacity
- Produces crystalline 13g cubes
- Production rated at 21°C air and 15°C water
- Hospital grade stainless steel outer
- Fully insulated internal storage bin
- Disappearing insulated door
- Electromechanical operation
- Stainless steel spray arm

STANDARD ACCESSORIES

- Water inlet hose
- Drainage hose
- External water filter
- Pressure limiting valve
- Plastic ice scoop
- Adjustable stainless steel legs (4)



13g Cubes

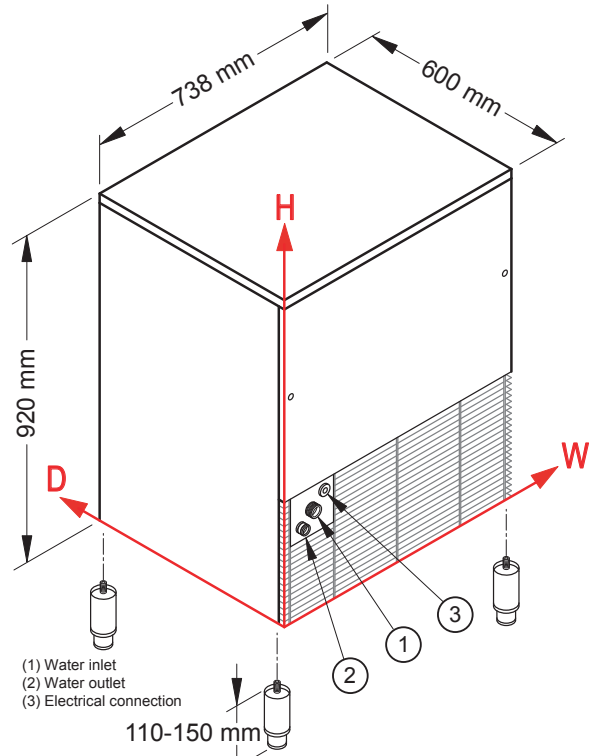
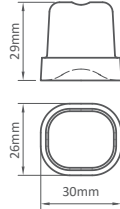

DIMENSIONS

738W x 600D x 920*H mm (*add 110-150mm for adjustable legs)

Clearances: Rear: 100mm Sides: 100mm

POWER SUPPLY

240V 50Hz 10A single phase (plugged)

CONNECTIONS

3/4" Water inlet, 24mm Water outlet & Electrical connection

	W	H
Water inlet	116mm	285mm
Water outlet	54mm	245mm
Electrical connection	161mm	321mm

TECHNICAL DATA

Energy Consumption:	650W
Production 24h:	67kg
Storage Capacity:	40kg
Cooling System:	Air
Cube:	13g
Refrigerant:	R404A
Weight:	77kg
WaterMark:	Yes

SPECIFICATIONS ARE SUBJECT TO CHANGE WITHOUT NOTICE.



National Head Office
 156 Swann Drive
 Derrimut VIC 3030
 Tel: +61 3 8369 4600
 Fax: +61 3 8369 4699
www.comcater.com.au

Melbourne
 96-100 Tope Street
 South Melbourne VIC 3205
 Tel: +61 3 8369 4600
 Fax: +61 3 8699 1299

Sydney
 20/4 Avenue of the Americas
 Newington, NSW 2127
 Tel: +61 2 9748 3000
 Fax: +61 2 9648 4762

Brisbane
 1/62 Borthwick Avenue
 Murarrie QLD 4172
 Tel: +61 7 3399 3122
 Fax: +61 7 3399 5311

Perth
 Unit 16, 7 Abrams Street
 Balcatta, WA 6021
 Tel: +61 8 6217 0700
 Fax: +61 8 6217 0799