



GB1555A

SELF-CONTAINED ICE FLAKER

Brema's GB range of self-contained ice flakers produces granular ice flakes and stores them in an internal storage bin.

The Brema GB1555A is a free-standing ice flaking machine that produces 155kg of granular ice per 24 hours and has storage capacity of 55kg.

Granular ice is ideal for exhibiting and presenting foods as well as for use in medical industries. The ice has a fast and efficient refrigerating effect and is easy to handle and dose.



Ice Flakes



STANDARD FEATURES

- 155kg production per 24 hours
- 55kg storage capacity
- Produces compact, granular flakes
- Production rated at 21°C air and 15°C water
- Hospital grade stainless steel outer
- Fully insulated internal storage bin
- Disappearing insulated door
- Electromechanical operation
- Powerful gear motor and auger system
- Water to ice ratio - 1L of water makes 1kg of ice

STANDARD ACCESSORIES

- Water inlet hose
- Drainage hose
- External water filter
- Pressure limiting valve
- Plastic ice scoop
- Adjustable stainless steel legs (4)

DIMENSIONS

738W x 690D x 1020*H mm (*add 110-150mm for adjustable legs)

Clearances: Rear: 100mm Sides: 100mm

POWER SUPPLY

240V 50Hz 10A single phase (plugged)

CONNECTIONS

3/4" Water inlet, 24mm Water outlet & Electrical connection

	W	H
Water inlet	104 mm	247 mm
Water outlet	53 mm	240 mm
Electrical connection	92 mm	319 mm

TECHNICAL DATA

Energy Consumption:	650W
Production 24h:	155kg
Storage Capacity:	55kg
Cooling System:	Air
Ice type:	Granular
Refrigerant:	R404A
Weight:	94kg
WaterMark:	Yes

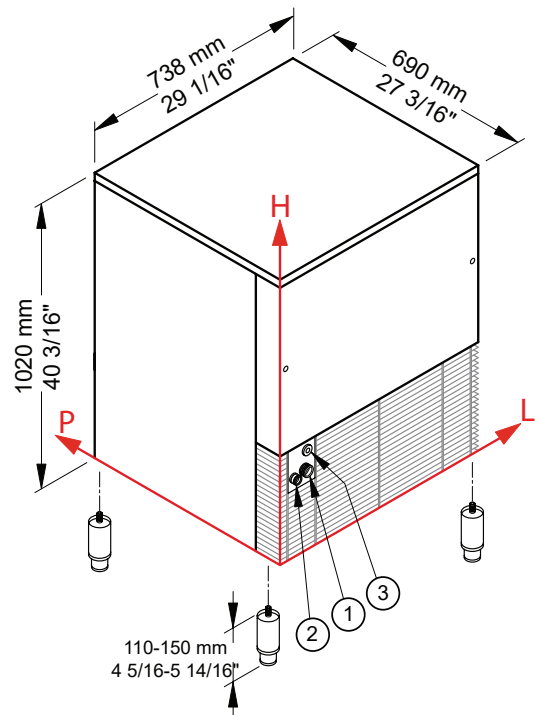

- ① Water in.
- ② Water out.
- ③ Electrical connections

SPECIFICATIONS ARE SUBJECT TO CHANGE WITHOUT NOTICE.



National Head Office
156 Swann Drive
Derrimut VIC 3030
Tel: +61 3 8369 4600
Fax: +61 3 8369 4699
www.comcater.com.au

Melbourne
96-100 Tope Street
South Melbourne VIC 3205
Tel: +61 3 8369 4600
Fax: +61 3 8699 1299

Sydney
20/4 Avenue of the Americas
Newington, NSW 2127
Tel: +61 2 9748 3000
Fax: +61 2 9648 4762

Brisbane
1/62 Borthwick Avenue
Murarrie QLD 4172
Tel: +61 7 3399 3122
Fax: +61 7 3399 5311

Perth
Unit 16, 7 Abrams Street
Balcatta, WA 6021
Tel: +61 8 6217 0700
Fax: +61 8 6217 0799