

PREMIER 2142

BENCHTOP VACUUM PACKER WITH GAS-FLUSH & SENSOR CONTROL

STANDARD FEATURES

- Stainless steel housing deep-drawn vacuum chamber for optimal hygiene
- Transparent lid
- Removable wireless sealing bar
- Insert plates for adjusting vacuum chamber height
- Vacuum - Optimal final vacuum 99.80% (2 mbar)
- Gas-flush - Injecting food-gas for product protection and longer shelf life
- Soft-air - Controlled ventilation for protection of product and packaging
- 2 x 3.5mm seal wires for an extra-strong double seal
- Sensor Control - Set percentage pressure for vacuum and gas functions for accurate and constant packaging results / Automatic programming / 10 default programs / Vacuum plus time
- STOP button for partial/full cycle interruption
- Digital maintenance program for pump / Operating hours counter / Service indicator programs / Sleeper function etc
- Service kit for user maintenance



DIMENSIONS

External: 493W x 616D x 440H mm

Chamber: 420W x 460D x 180H mm

Sealing Bar: 420mm

Weight: 67Kg

TECHNICAL DATA

Power Supply: 240V, 50Hz, Single Phase

Power Output: 1.0kW

Capacity pump: 21 m³/h

Machine cycle: 20-40 seconds

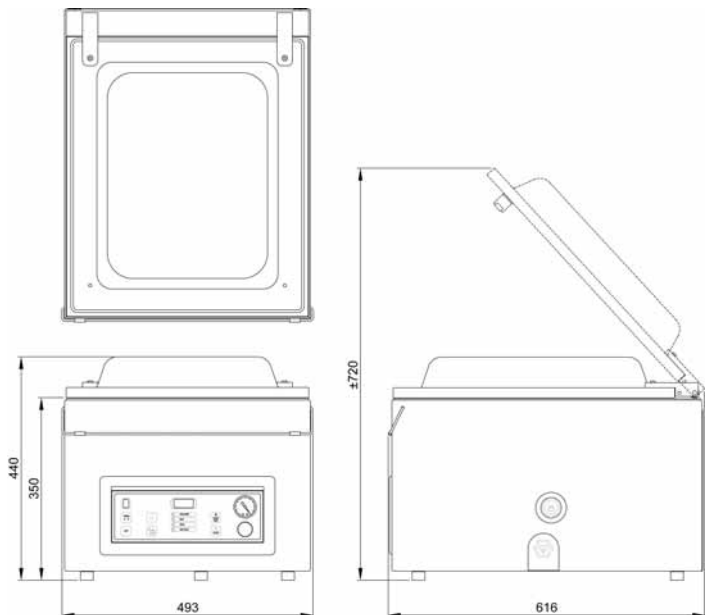

OPTIONS

- Inclined insert plate for packing liquid products
- Trolleys with 3 shelves and lockable castors



Busch vacuum pumps, world leaders in vacuum pump technology



Two years parts and labour warranty

SPECIFICATIONS ARE SUBJECT TO CHANGE WITHOUT NOTICE.

From the world of Comcater!

National Head Office
156 Swann Drive
Derrimut VIC 3030
Tel: +61 3 8369 4600
Fax: +61 3 8369 4695

Melbourne
96-100 Tope Street,
South Melbourne VIC 3205
Tel: +61 3 8369 4600
Fax: +61 2 8699 1299

Sydney
20/4 Avenue of the Americas
Newington, NSW 2127
Tel: +61 2 9748 3000
Fax: +61 2 9 648 4762

Brisbane
1/62 Borthwick Avenue
Murarrie QLD 4172
Tel: +61 7 3399 3122
Fax: +61 7 3399 5311